



# AGUA CALIENTE

NWC 70th St & Shea Blvd | Scottsdale, AZ



## CO-TENANTS



## AT A GLANCE

	<b>ESTIMATED POPULATION</b> (5 MILE RADIUS) 192,542		<b>AVERAGE INCOME</b> (5 MILE RADIUS) \$92,951		<b>YEAR BUILT</b> 1987
---	---	---	--	---	---------------------------

## PROPERTY HIGHLIGHTS

- A 50,000 square foot neighborhood center comprised of specialty shops, restaurants & services.
- Located in the heart of central Scottsdale, just minutes from Paradise Valley, Gainey Ranch and McCormick Ranch.
- Strategically nestled within a highly dense & accessible retail trade area.

## AVAILABLE UNITS

SUITE 125	943 SF	Office/Retail
SUITE 215	2,341 SF	Office/Retail

Agua Caliente is ideally situated on Shea Blvd, just west of Scottsdale Rd. It offers a dynamic mix of restaurants, retailers and business services. This commercial property is located in the geographic center of Scottsdale which caters to an affluent demographic and significant tourist population

For more information please contact:

**MARTA KENNY**  
480.696.4812  
marta@yamproperties.com



# AGUA CALIENTE

NWC 70th St & Shea Blvd | Scottsdale, AZ

## AREA CO-TENANTS

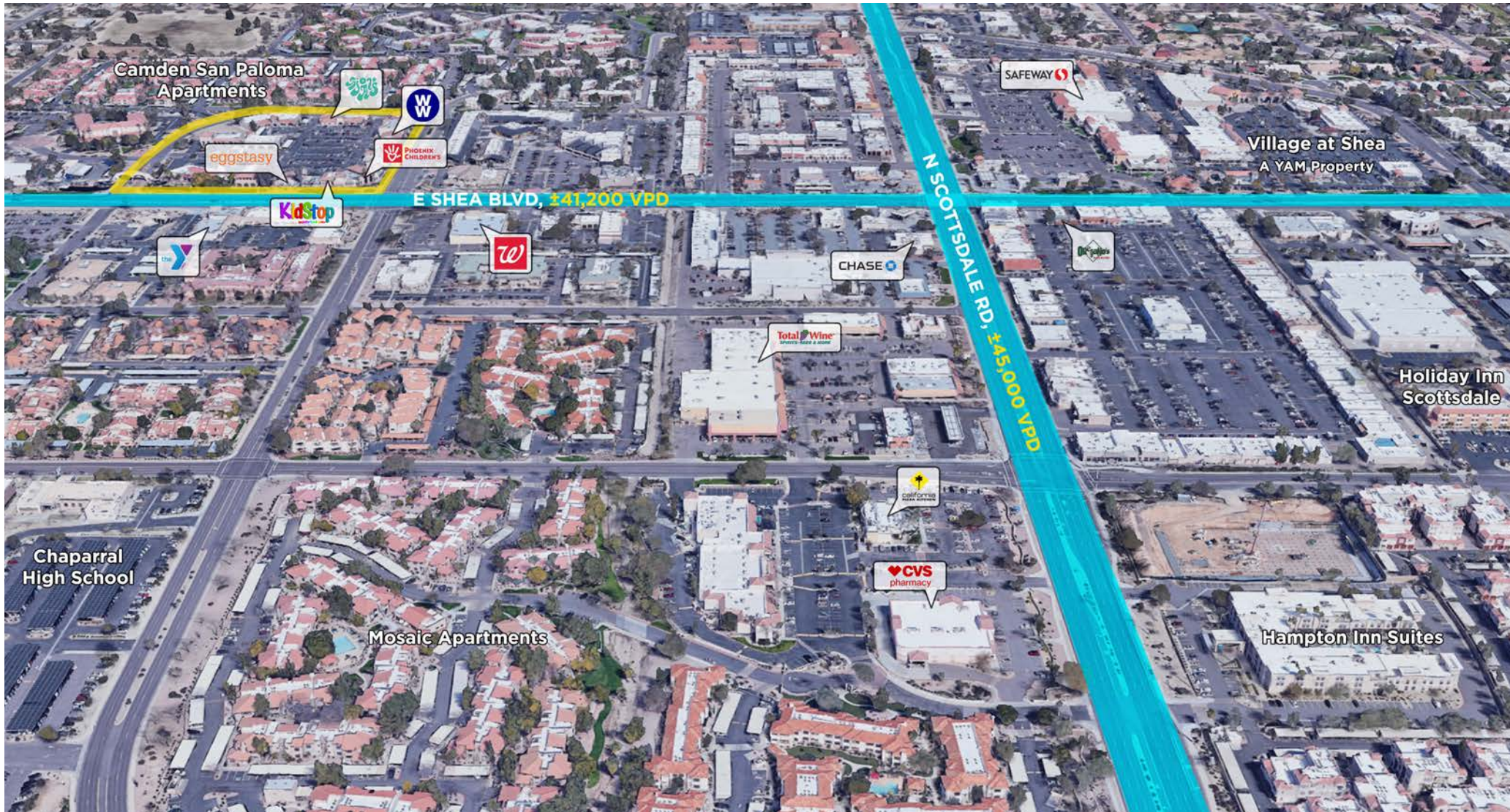

For more information please contact:

**MARTA KENNY**

480.696.4812

[marta@yamproperties.com](mailto:marta@yamproperties.com)



[yamproperties.com](http://yamproperties.com)



# AGUA CALIENTE

NWC 70th St & Shea Blvd | Scottsdale, AZ

## SITE MAP

### DINING

- 16** Ajo Al's Mexican Cafe
- 15** Eggstasy

### AVAILABLE

- 9** Suite 215
- 17** Suite 125

### OFFICE

- 7** Zona Egg, LLC

### SERVICES

- 1** Brightmont Academy
- 6** Music Masters
- 5** Just 3 Little Letters
- 13** Phoenix Children's Hospital
- 3** Strictly Chiropractic
- 12** Sweet Sunshine Nails
- 11** Urban Edge Salon
- 10** Urban Garage Gym
- 4** Weight Watchers

### SHOPPING

- 18** BeStitched Needlepoint
- 14** Kidstop Toys & Books
- 6** Music Masters
- 8** Sweet Medicine Shoppe
- 2** Zak's Chocolate



For more information please contact:

**MARTA KENNY**

480.696.4812

marta@yamproperties.com



yamproperties.com

# AGUA CALIENTE

NWC 70th St & Shea Blvd | Scottsdale, AZ

FLOOR PLANS

## SUITE 215 | #9

6990 E Shea Blvd | Scottsdale, AZ 85254

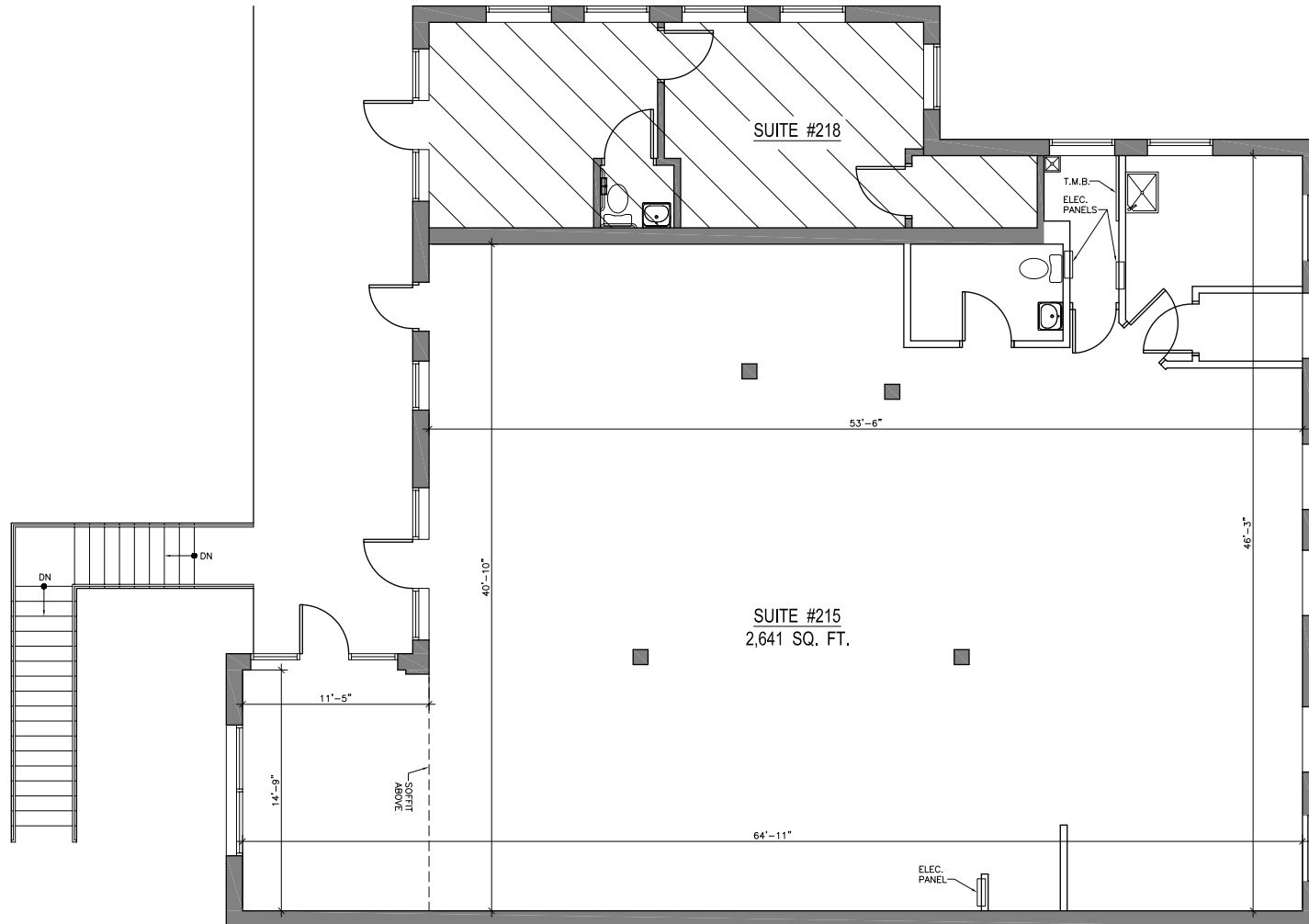

For more information please contact:

**MARTA KENNY**

480.696.4812

marta@yamproperties.com



yamproperties.com

# AGUA CALIENTE

NWC 70th St & Shea Blvd | Scottsdale, AZ

FLOOR PLANS

## SUITE 125 | #17

6990 E Shea Blvd | Scottsdale, AZ 85254

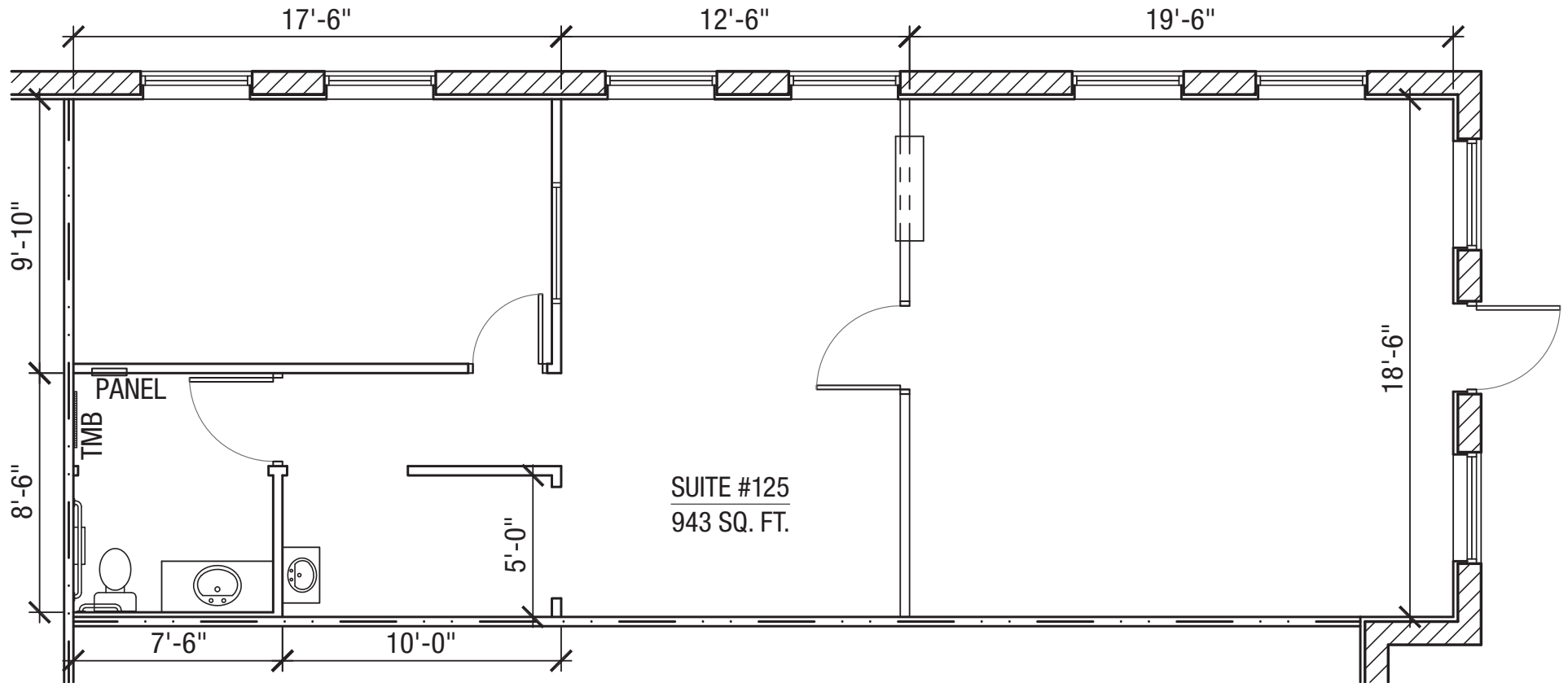

For more information please contact:

**MARTA KENNY**

480.696.4812

marta@yamproperties.com

**yam**  
PROPERTIES

yamproperties.com

# AGUA CALIENTE

NWC 70th St & Shea Blvd | Scottsdale, AZ

PHOTOS



For more information please contact:

**MARTA KENNY**

480.696.4812

marta@yamproperties.com



yamproperties.com

# AGUA CALIENTE

NWC 70th St & Shea Blvd | Scottsdale, AZ

## DEMOGRAPHICS

Radius	1 mile		3 mile		5 mile	
<b>Population</b>						
2025 Population	7,390		67,446		205,848	
2020 Estimate	6,992		63,069		192,542	
2010 Census	6,833		56,846		173,803	
Growth 2020 - 2025	5.69%		6.94%		6.91%	
Growth 2010 - 2020	2.33%		10.95%		10.78%	
<b>Population by Hispanic Origin</b>	<b>462</b>		<b>3,502</b>		<b>15,535</b>	
<b>2020 Population</b>	<b>6,992</b>		<b>63,069</b>		<b>192,542</b>	
White	6,264	89.59%	57,619	91.36%	172,143	89.41%
Black	199	2.85%	986	1.56%	4,137	2.15%
American Indian & Alaskan	32	0.46%	339	0.54%	1,546	.80%
Asian	329	4.71%	2,797	4.43%	10,052	5.22%
Hawaiian & Pacific Island	4	0.06%	57	0.09%	230	0.12%
Other	164	2.35%	1,272	2.02%	4,434	2.30%
U.S. Armed Forces	0		13		81	

Radius	1 mile		3 mile		5 mile	
<b>Households</b>						
2025 Projection	3,273		28,663		90,251	
2020 Estimate	3,121		26,909		84,646	
2010 Census	3,186		24,837		77,568	
Growth 2020 - 2025	4.87%		6.52%		6.62%	
Growth 2010 - 2020	-2.04%		8.34%		9.12%	
Owner Occupied	1,723	55.21%	20,153	74.89%	56,824	67.13%
Renter Occupied	1,398	44.79%	6,757	25.11%	27,822	32.87%
<b>2020 Households by HH Income</b>	<b>3,121</b>		<b>26,909</b>		<b>84,646</b>	
Income: <\$25,000	343	10.99%	2,199	8.17%	7,641	9.03%
Income: \$25,000 - \$50,000	526	16.85%	3,562	13.24%	12,979	15.33%
Income: \$50,000 - \$75,000	399	12.78%	3,379	12.56%	13,387	15.82%
Income: \$75,000 - \$100,000	416	13.33%	3,422	12.72%	11,581	13.68%
Income: \$100,000 - \$125,000	300	9.61%	2,818	10.47%	9,459	11.17%
Income: \$125,000 - \$150,000	201	6.44%	2,059	7.65%	6,095	7.20%
Income: \$150,000 - \$200,000	241	7.72%	2,714	10.09%	8,144	9.62%
Income: \$200,000+	695	22.27%	6,755	25.10%	15,360	18.15%
<b>2020 Avg Household Income</b>	<b>\$129,298</b>		<b>\$142,781</b>		<b>\$124,513</b>	
<b>2020 Med Household Income</b>	<b>\$92,577</b>		<b>\$107,913</b>		<b>\$92,951</b>	

For more information please contact:

**MARTA KENNY**

480.696.4812

marta@yamproperties.com



yamproperties.com